



www.skyjacker.com

2014 - 2020 Ram 2500 4WD
2013 - 2020 Ram 3500 4WD
Dual Steering Stabilizer
Part # 7214 / 8214 / 9214

REQUIRED TOOL LIST:

- Safety Glasses
- Metric / Standard Wrenches & Sockets
- Measuring Tape
- Torque Wrench

Before beginning the installation, thoroughly & completely read these instructions & the enclosed driver's WARNING NOTICE. Affix the WARNING decal in the passenger compartment in clear view of all occupants. Please refer to the Parts List to insure that all parts & hardware are received prior to the disassembly of the vehicle. If any parts are found to be missing, contact SKYJACKER® Customer Service at 318-388-0816 to obtain the needed items. If you have any questions or reservations about the installation of this product, contact SKYJACKER® Technical Assistance at 318-388-0816.

Important Note:

- This steering stabilizer kit is designed for vehicles with a minimum of 4" of lift. Do not attempt to install this steering stabilizer kit on a vehicle with less than 4" of lift.

Component Box Breakdown:

Part #: 7214 / 8214 / 9214

Item #	Description	Qty	Item #	Description	Qty
7000WS	WHITE STEERING DAMPER (Included With 7214)	2	BTIE-K	BLACK BOOT TIE (Included With 8214 & 9214)	2
8000BS	BLACK STEERING DAMPER (Included With 8214)	2	HSS	HYDRO SHOCK DECAL (Included With 7214)	2
9000WS	SILVER STEERING DAMPER (Included With 9214)	2	SSD	SILVER STABILIZER DECAL (Included With 9214)	2
7214-MB	MAIN BRACKET	1	MXSD	BLACK MAX STABILIZER DECAL (Included With 8214)	2
B10RS	RED BOOT (Included With 7214)	2	HB-7214	HARDWARE BAG: 7214 / 9214 (Included With 7214 & 9214)	1
B10KS	BLACK BOOT (Included With 8214 & 9214)	2	HB-8214	HARDWARE BAG: 8214 (Included With 8214)	1
BTIE	RED BOOT TIE (Included With 7214)	2	I-7214	INST SHEET: 7214 / 9214	1

Hardware Bag Breakdown:

Part # HB-7214 / HB-8214

Item #	Description	Qty	Item #	Description	Qty
7214-6	FRONT PLATE BRACKET	1	516X134X258U	5/16 X 1 3/4 X 2 5/8 U-BOLT	2
7218-DB	TIE ROD BRACKET / PASS	1	516SAEW	5/16 SAE WASHER	8
7254-PB	TIE ROD BRACKET / DRIVER	1	516CTN	5/16 COARSE THR LOCK NUT	8
CS0438	CRUSH SLEEVE. .438" LONG	2	140629	EB6 STUD BAG - P932/140629	4
10MMX30MMB	10MM X 30MM METRIC BOLT	2	HOURGLASS 5/8	HOURGLASS 5/8 BUSH / RED (Included With 7214)	4
38X4X558U	3/8 X 4 X 5 5/8 U-BOLT	1	HG5815-K	HOURGLASS 5/8 BUSH / BLK (Included With 8214)	4
38SAEW	3/8 SAE WASHER	4			
38FTN	3/8 FINE THREAD LOCK NUT	2			
516X112X214U	5/16 X 1 1/2 X 2 1/4 U-BOLT	2			

Installation:

1. Park the vehicle on a level concrete or asphalt surface with the front tires / wheels pointing straight forward.
2. Set the emergency brake & block the rear tires / wheels.
3. Remove the OEM steering stabilizer using a 18mm socket. (See Photo # 1)
4. Remove the OEM steering stabilizer axle bracket using a 13mm socket. (See Photo # 2)
5. Remove the OEM driver's side tie rod clamp using an 18mm socket & rotate the OEM driver's side tie rod clamp 180 degrees. Install the driver's side tie rod clamp hardware with the nut facing toward the rear of the vehicle & tighten using a 18mm socket. (See Photo # 3)
6. Install the new Skyjacker main bracket to the upper axle mounting locations using the supplied crush sleeves, 10mm x 30mm bolts, washers, & a 17mm socket. **Note:** The new crush sleeves will be installed between the axle & the new main bracket. (See Photo # 4)

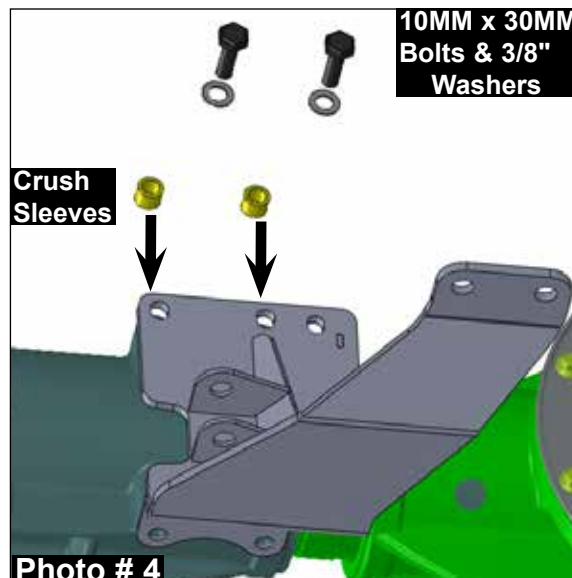

7. Install the new Skyjacker main bracket to the lower axle mounting locations using the OEM hardware & a 13mm socket. (See Photo # 5)
8. Install the new Skyjacker 3/8" x 4" x 5 5/8" u-bolt from the rear of the axle tube using the supplied 3/8" washers, nuts, & a 9/16" socket. (See Photo # 6)
9. Install the OEM steering stabilizer to the new Skyjacker main bracket using the OEM hardware & a 18mm socket. **Note:** Install the OEM bolt at the new main bracket with the head of the bolt facing upward. (See Photo # 7)
10. Install two of the new Skyjacker shock studs to the top of the new Skyjacker main bracket using the supplied 1/2" washers, nuts & a 3/4" socket. (See Photo # 8)
11. Install the new Skyjacker passenger side tie rod bracket (Part # 7218-DB) to the OEM tie rod assembly using the supplied 5/16" x 1 3/4" x 2 5/8" u-bolts, washers, nuts, & a 1/2" socket. **Note:** Do not tighten at this time. (See Photo # 9)

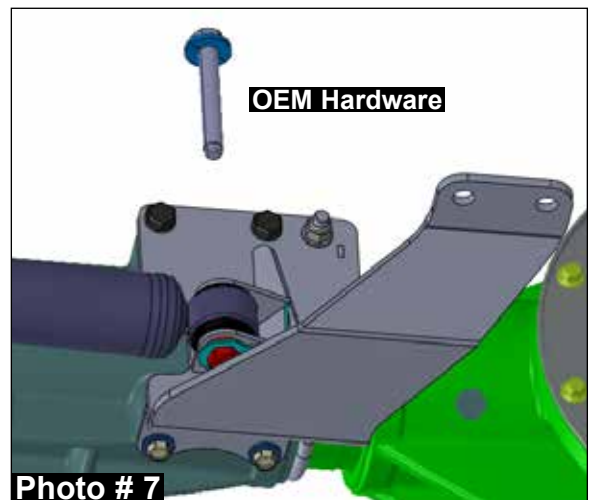
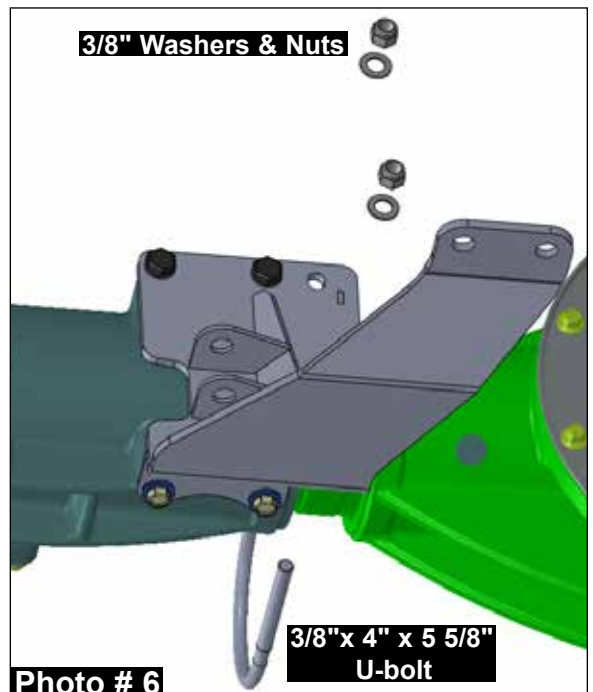
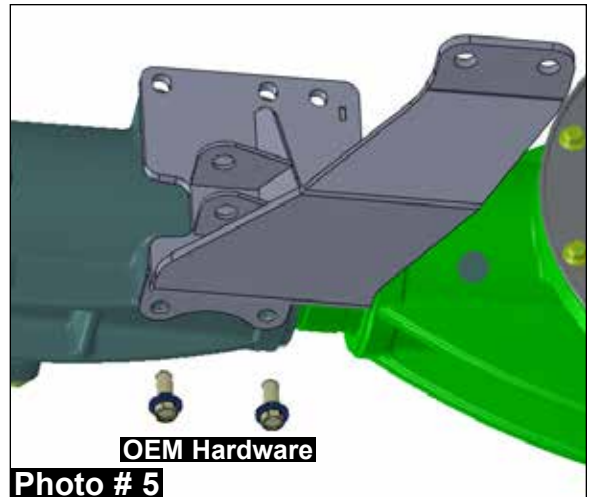

12. Install the new Skyjacker driver side tie rod bracket (Part # 7254-PB) to the OEM tie rod assembly using the supplied 5/16" x 1 1/2" x 2 1/4" u-bolts, washers, nuts, & a 1/2" socket. **Note:** Do not tighten at this time. (See Photo # 10)

13. Install a new Skyjacker shock stud to the top of each new Skyjacker tie rod bracket using the supplied 1/2" washers, nuts & a 3/4" socket. (See Photos # 9 & # 10)

14. Assemble the new Skyjacker steering stabilizer cylinders using the supplied shock boots, plastic ties, & hourglass bushings.

15. Install the new Skyjacker steering stabilizer cylinders onto the new shock studs of the new main bracket using the supplied Skyjacker name plate, 1/2" washers, nuts, & a 3/4" socket. (See Photo # 11)

16. Pull the shafts of the new Skyjacker steering stabilizer cylinders out 4 1/4" & install the new steering stabilizer cylinders onto the new shock studs of the new tie rod brackets using the supplied 1/2" washers, nuts, & a 3/4" socket. (See Photo # 12)

17. Adjust the new Skyjacker tie rod brackets to align with the new Skyjacker steering stabilizer cylinders & tighten the new 5/16" u-bolt hardware using a 1/2" socket.

Final Notes:

- After the installation is complete, double check that all nuts & bolts are tight. Refer to the following chart for the proper torque specifications. (Do not retighten the nuts & bolts where thread lock compound was used.)
- Cycle the steering of the vehicle left to right & check all parts for adequate clearance.
- After the first 100 miles, check all hardware for the proper torque & periodically thereafter.

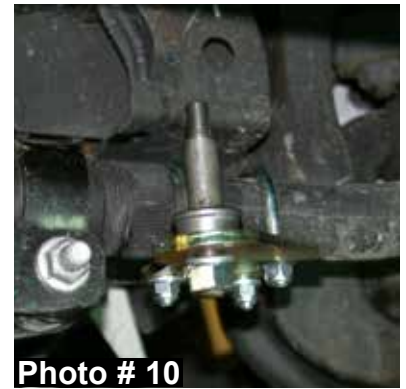

TORQUE SPECIFICATIONS

<u>INCH SYSTEM</u>			<u>METRIC SYSTEM</u>		
Bolt Size	Grade 5	Grade 8	Bolt Size	Class 8.8	Class 10.9
5/16	15 FT LB	20 FT LB	6MM	5 FT LB	9 FT LB
3/8	30 FT LB	35 FT LB	8MM	18 FT LB	23 FT LB
7/16	45 FT LB	60 FT LB	10MM	32 FT LB	45 FT LB
1/2	65 FT LB	90 FT LB	12MM	55 FT LB	75 FT LB
9/16	95 FT LB	130 FTLB	14MM	85 FT LB	120 FT LB
5/8	135 FT LB	175 FT LB	16MM	130 FT LB	165 FT LB
3/4	185 FT LB	280 FT LB	18MM	170 FT LB	240 FT LB

- The above specifications are not to be used when the bolt is being installed with a bushing.

Seat Belts Save Lives, Please Wear Your Seat Belt.



Jesus Christ Died For You.

John 3:16

For God so loved the world that He gave His only Son, so that everyone who believes in Him should not perish, but have everlasting life.
Romans 3:23

For all have sinned; all fall short of God's glorious standard.
Ephesians 2:8

God saved you by his special favor when you believed. And you can't take credit for this; it is a gift from God.
Psalms 18:2

The Lord is my Rock, my fortress, and my savior; my God is my Rock, in whom I find protection. He is my shield, the strength of my salvation, and my stronghold.
Romans 10:9-10

That if you shall confess with thy mouth the Lord Jesus, and shall believe in your heart that God hath raised him from the dead, you shall be saved. For with the heart man believeth unto righteousness; and with the mouth confession is made unto salvation.

Pray This Simple Prayer:

God, I come to You admitting I have sinned against You and I need you to take control of my life. The Bible says anyone who calls on the name of the Lord will be saved. I am calling on You, Jesus. I ask that You come live in my heart and be the Lord over my life today. I do believe You died on the cross for me and came back to life to give me life! Thank You, Lord Jesus for a new life in You!

Now, go and tell somebody about your new life in Jesus, get a Bible, begin to read it, and go to a Bible believing church.

If you would like someone to pray with you, call Kenneth Copeland Ministries anytime at 800-600-7395.

To listen to commercial free Christian radio on the web, go to www.887fm.org

Jesús murió por ti.

Juan 3:16

“Porque tanto amó Dios al mundo, que dio a su Hijo unigénito, para que todo el que cree en él no se pierda, sino que tenga vida eterna.”
Romanos 3:23

“Pues todos han pecado y están privados de la gloria de Dios.”
Efesios 2:8

“Porque por gracia ustedes han sido salvados mediante la fe; esto no procede de ustedes, sino que es el regalo de Dios.”
Salmos 18:2

“El Señor es mi roca, mi amparo, mi libertador; es mi Dios, el peñasco en que me refugio. Es mi escudo, el poder que me salva, ¡mi más alto escondite!”
Romanos 10:9-10

“9 Que si confi esas con tu boca que Jesús es el Señor, y crees en tu corazón que Dios lo levantó de entre los muertos, serás salvo. 10 Porque con el corazón se cree para ser justificado, pero con la boca se confiesa para ser salvo.”

Ahora dí esta simple oración:

Dios, vengo a Ti y admito que he pecado contra Ti, necesito que tomes el control de mi vida. La Biblia dice que todo aquel que invoca el nombre del Señor escapará con vida. En este momento yo clamo ante Ti, Jesús; te pido que vengas a vivir en mi corazón y que tomes el control de mi vida. ¡Yo creo que tu moriste en la cruz y resucitaste para darme vida! ¡Gracias Señor Jesús, por una nueva vida que tengo en Ti! Amen.

Ahora ve y dile a alguien sobre la nueva vida que tienes en Cristo. Compra una Biblia y empieza a leerla. Busca una Iglesia que cree en la Biblia y hazte parte de esa Iglesia.

Si te gustaría orar con alguien, puedes llamar a este número 800-600-7395

Puedes ir a este sitio de Internet para escuchar música Cristiana sin anuncios, www.887fm.org

Check out our favorite ministries at:

www.innministries.org

www.familychurch.org

www.kcm.org

