



www.skyjacker.com

2011 Chevy/GMC K2500HD 4WD 2" Torsion Bar Keys Installation Instructions

REQUIRED TOOL LIST:

- Metric / Standard Wrenches & Sockets
- Floor Jack
- Jack Stands
- Measuring Tape
- Torsion Bar Tool



Before beginning the installation, thoroughly & completely read these instructions, the enclosed driver's WARNING NOTICE & affix the WARNING decal in the passenger compartment in clear view of all occupants. Please refer to the Parts List to insure that all parts & hardware are received prior to the disassembly of the vehicle. If any parts are found to be missing, contact SKYJACKER® Customer Service at 318-388-0816 to obtain the needed items. If you have any questions or reservations about installing this lift kit, call SKYJACKER® Technical Assistance at 318-388-0816.

Make sure you park the vehicle on a level concrete or asphalt surface. Many times a vehicle is not level (side-to-side) from the factory & is usually not noticed until a lift kit has been installed which makes the difference more visible. Using a measuring tape, measure the front (both sides) from the ground up to the center of the fender opening above the axle. Record this information below for future reference.

Driver Side Front: _____ Passenger Side Front: _____

Important Notes:

- If larger tires (10% more than the stock diameter) are installed, speedometer recalibration will be necessary. Contact your local Chevy / GMC dealer or an authorized dealer for details.
- After installation a qualified alignment facility is required to align the vehicle to factory specifications.

Kit Box Breakdown:

Part #: C115KE

<u>ITEM#</u>	<u>DESCRIPTION</u>	<u>QTY</u>
C115KE-S	2" TORSION KEY,11 GM 2500HD	2
HB-C115KE	HDWR BAG: C115KE T/BAR KEYS	1
I-C115KE	INSTRUCTION SHEET: C115KE	1

Hardware Bag Breakdown:

HB-C115KE **HARDWARE BAG**

<u>ITEM#</u>	<u>DESCRIPTION</u>	<u>QTY</u>
12XTFW	1/2"EXTRA THICK FLAT WASHER	8

Important Notes:

- The net amount of ride height increase depends upon the age & use of the vehicle, wheel offset, & numerous other factors. Stated torsion bar ride height increases are based upon the factory specifications. If the torsion bars were "cranked up" at some point in the past, expect a corresponding reduction in the overall height increase with the new torsion keys.
- The torsion bars, like any other spring, are subject to fatigue & sagging over time. Also, torsion bars have different ratings depending on how the vehicle was equipped from the factory. In some cases, installing heavier rated torsion bars (which can be purchased from a GM dealer) may be the only solution to regaining ride height lost from adding heavy aftermarket accessories, such as a winch bumper or snow plow.
- Various types of torsion bar removal tools are available, however, due to the extreme loads present in torsion bar suspension systems, we have found the two-jaw style removal tool that clamps to the cross member tends to slip & damage the crossmember. A C-clamp style removal tool (Kent - Moore Part # CH-48809) is preferred & can be purchased from a GM dealer or auto parts store.

Front Installation:

1. Place the vehicle on a level concrete or asphalt surface.
2. Put the transmission in Park or 1st gear (manual transmissions) & chock the rear tires.
3. Raise the front of the vehicle using a jack. Raise the vehicle enough to completely unload the front suspension. Place a jack stand under each frame rail just behind the lower control arms of the front suspension & lower the frame of the vehicle onto the jack stands.
4. Verify the front tires / wheels are off the ground & that the suspension is unloaded or at the full extension of travel.

5. Locate the torsion bar cross member. There is a bolt on each side of the cross member that adjusts the torsion bar preload. Measure or mark the exposed length of the adjuster bolt for reference during reassembly. (See Photo # 1)
6. Position the appropriate torsion bar removal tool on the cross member. **Note:** Be sure the top of the torsion bar removal tool engages the recess present in most cross members & the lower end of the torsion bar removal tool engages the recess on the torsion key near the adjuster bolt. (See Photo # 2)
7. Using extreme caution, tighten the torsion bar removal tool enough to take the load off of the adjuster bolt & remove the adjuster bolt & nut block. Once removed, unload the torsion bar removal tool.
8. Note the orientation of the torsion bar key in relation to the end of the torsion bar. Slide the torsion bar forward, out of the torsion bar cross member & set the factory torsion bar key aside. It is not necessary to remove the torsion bars from the vehicle. **Note:** The torsion bar key should slide easily off the end of the torsion bar. However, depending on the age & use of the vehicle, rust & road debris may prevent easy removal. The installer can use a variety of methods to separate the torsion bar key if it is "stuck". However, using heat to separate the torsion bar key from the torsion bar is not recommended.

Photo # 1

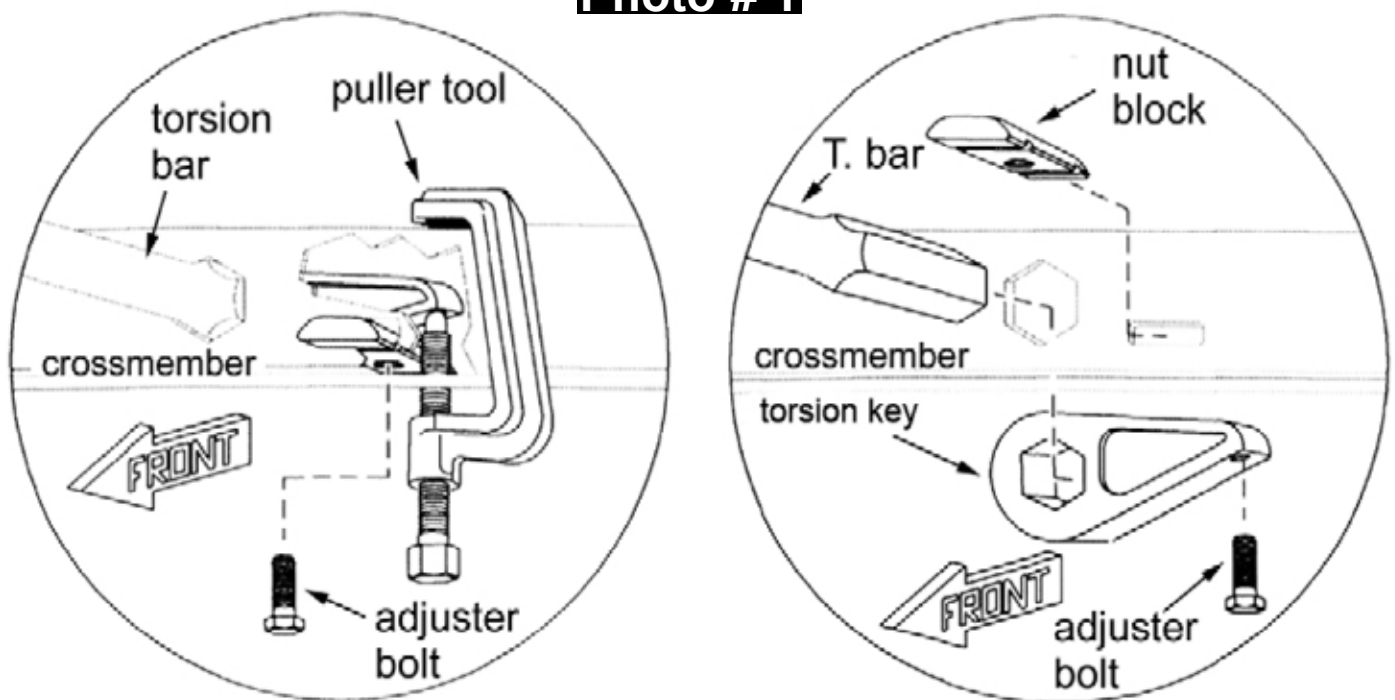
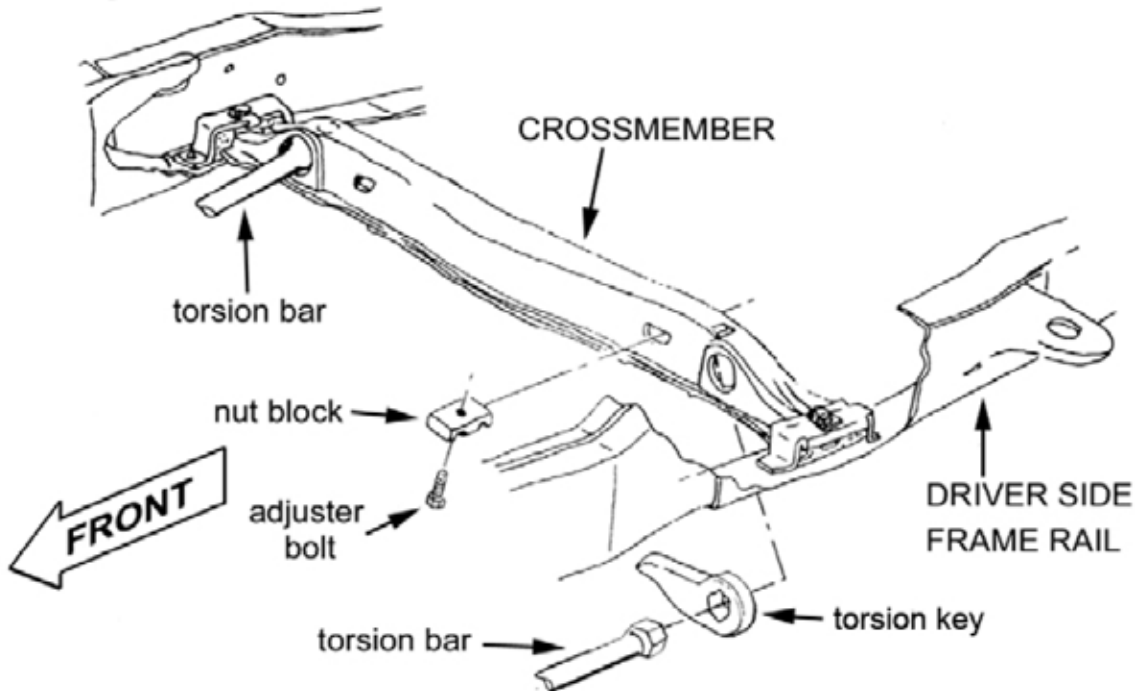

Photo # 2 - TORSION BAR ASSEMBLY.



9. Remove the front shock & install two of the supplied 1/2" extra thick washers onto each upper stud of the front shock. Once two of the 1/2" extra thick washers have been installed onto each upper stud of the front shock, reinstall the front shock using the factory hardware. (See Photo # 3)

10. Place the new Skyjacker Suspension torsion bar key in the torsion bar cross member, matching the same orientation as the factory torsion bar key. Slide the torsion bar back through the cross member & into the new torsion bar key. (See Photo # 2)



11. Using the same precautions & procedures that were used during removal, load the torsion bar enough to install the nut block using the appropriate torsion bar removal tool. Place the nut block back in the cross member & start the adjuster bolt. Tighten the adjuster bolt to the same exposed length noted during disassembly. Unload & remove the torsion bar removal tool.

12. Lower the vehicle to the ground & manually bounce the front of the vehicle several times, enough to settle the suspension.

13. Measure the ride height on each side of the vehicle. To raise the height, tighten the torsion bar adjuster bolt (with vehicle off the ground), to lower ride height, loosen the adjuster bolt. The new torsion bar key is capable of increasing the ride height 2" over the factory specifications.

Note: Do not increase the ride height above this 2" specification or premature ball joint failure will occur.

Final Notes:

- After the installation is complete, double check that all nuts & bolts are tight. Refer to the following chart again for the proper torque specifications. (Do not retighten the nuts & bolts where thread lock compound was used.)
- With the vehicle placed on the ground, cycle the steering lock to lock & inspect the steering, suspension, driveline systems, & brake line systems for proper operation, tightness, & adequate clearance.
- Have the headlights readjusted to the proper settings.
- Have a qualified alignment center realign the front end to the factory specifications.
- Retorque all the bolts after the first 100 miles.

TORQUE SPECIFICATIONS					
INCH SYSTEM			METRIC SYSTEM		
Bolt Size	Grade 5	Grade 8	Bolt Size	Class 8.8	Class 10.9
5/16	15 FT LB	20 FT LB	6MM	5 FT LB	9 FT LB
3/8	30 FT LB	35 FT LB	8MM	18 FT LB	23 FT LB
7/16	45 FT LB	60 FT LB	10MM	32 FT LB	45 FT LB
1/2	65 FT LB	90 FT LB	12MM	55 FT LB	75 FT LB
9/16	95 FT LB	130 FTLB	14MM	85 FT LB	120 FT LB
5/8	135 FT LB	175 FT LB	16MM	130 FT LB	165 FT LB
3/4	185 FT LB	280 FT LB	18MM	170 FT LB	240 FT LB

***The above specifications are not to be used when the bolt is being installed with a bushing.**

Seat Belts Save Lives, Please Wear Your Seat Belt.