



2006 Honda Ridgeline 2" Suspension Lift Instruction Sheet

PARTS LIST:

ITEM#	DESCRIPTION	QTY
FRCS2-S	FRONT COIL SPACER,2"	2
RRCS2-S	REAR COIL SPACER,2"	2
10MMX30MMB	10 X 30 METRIC BOLT/ 10.9	12
10MMN	10 MM N/I LOCKNUT	12
38SAEW	3/8 SAE WASHER	18
10X30x1.25MMB	10 X 30 MET. BOLT 1.25 THRD PTCH	6



FRONT INSTALLATION:

1. Set the emergency brake and block the rear tires. Raise the front of the vehicle and properly support using jack stands. Remove front tires.
2. Disconnect stabilizer link (A) from damper (B). Remove the wheel sensor harness clips (C) and the brake line bracket (D) from the damper. Do not disconnect the wheel sensor connector. (See Image# 1)
3. Remove the damper pinch bolts (A) and flange nuts (B) from the damper. (See Image #2)
4. From under the hood, remove the service caps (A), and remove the three flange nuts (B) from the top of the damper, then remove the damper assembly. (See Image #3)
NOTE: Damper Assembly's are different left to right. Be sure to mark as L and R before you continue.
5. Locate the new front spacer. **NOTE:** The front spacers are not notched on the front side, the rear spacers are notched. Spacer will install, long end towards the front.
6. Attach the new front spacer to the factory frame mount using the 10mm x 30mm bolts (Grade 10.9) and nuts supplied. Bolts will install from the center of the bracket up into factory mount. One washer. Leave loose. (See Image #4) With bracket installed, attach damper to the new bracket using the factory hardware.

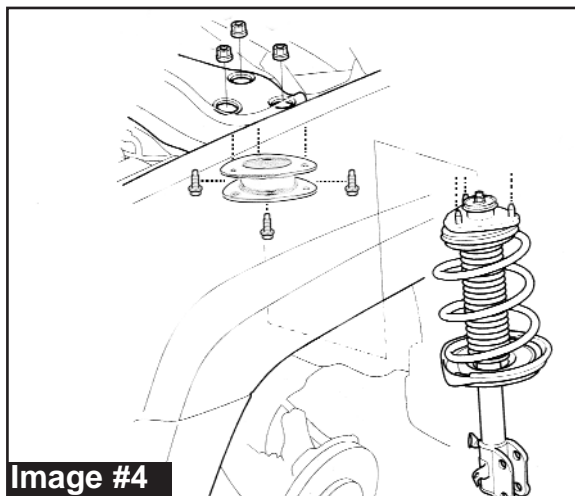
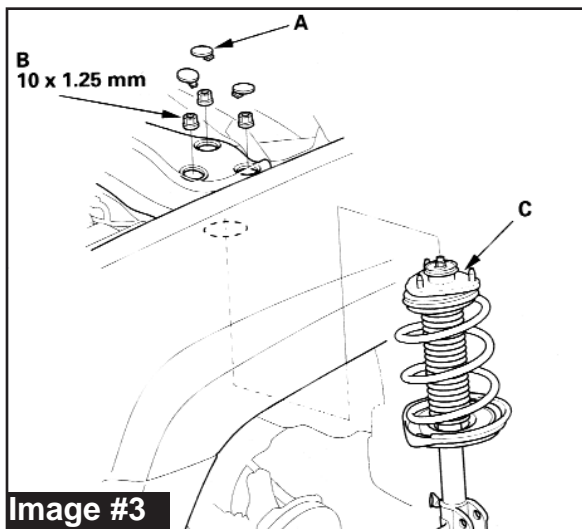
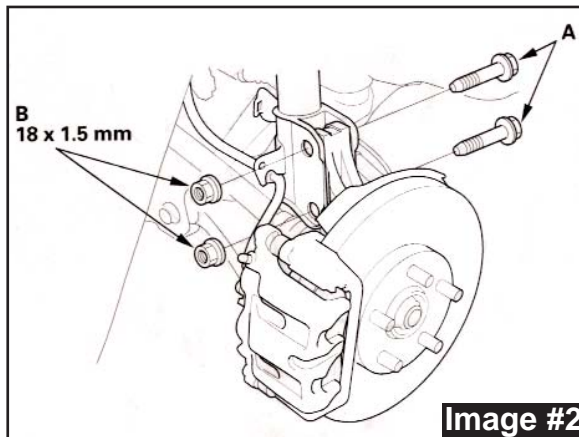
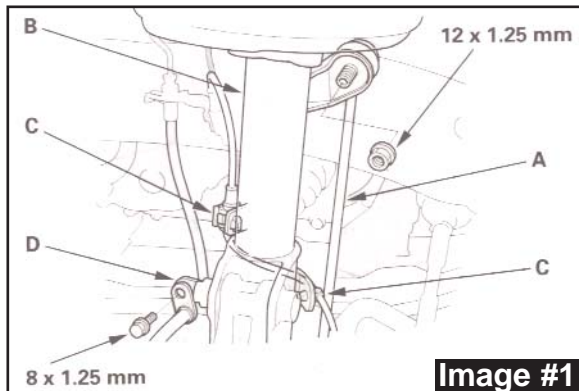

7. Attach damper assembly to the knuckle using the factory pinch bolts. Do not tighten at this time. **(See Image #5)**
8. Install the wheel sensor harness clips **(A)** and the brake line bracket **(B)** to the damper **(C)**. **(See Image #6)**
9. Loosely attach the stabilizer link **(D)** to the damper. Raise the front suspension with a floor jack to load the suspension with the vehicles weight. Tighten the damper pinch bolts and flange nuts. Torque to 156 Ft. Lbs. Torque upper bolts in top of upper bracket to 45 Ft. Lbs.
10. Torque the stabilizer link nuts to 58 Ft. Lbs.
11. Install factory service caps and front wheels.

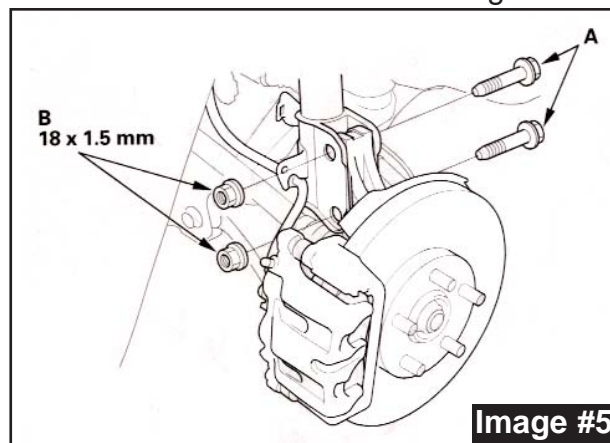

REAR INSTALLATION:

12. Raise the rear of the vehicle and properly support using jack stands. Remove the rear wheels.
13. Position a floor jack at the connecting point of the lower arm **(B)** and the knuckle. **(See Image #7)**
14. Remove the locknut **(B)**, washer **(C)** and flange bolt **(D)**. **(See Image #8)**.
15. On lower A-Arm, Remove locknut **(A)**, then remove flange bolt **(C)**. Remove flange bolt **(D)**, and lower the floor jack gradually. **(See Image #9)**

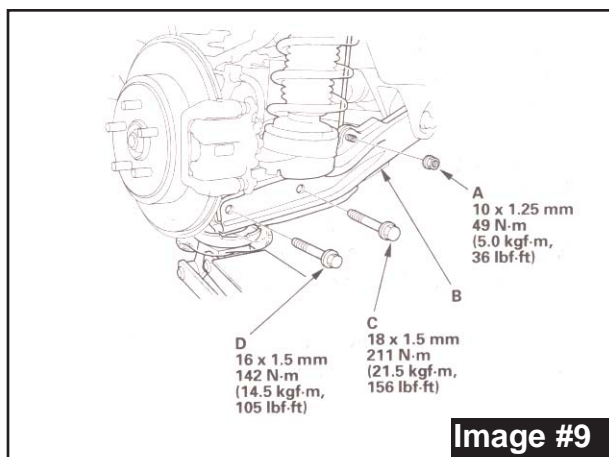
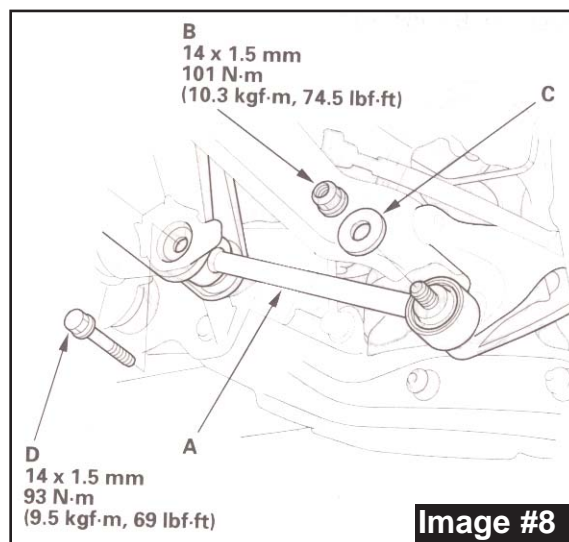
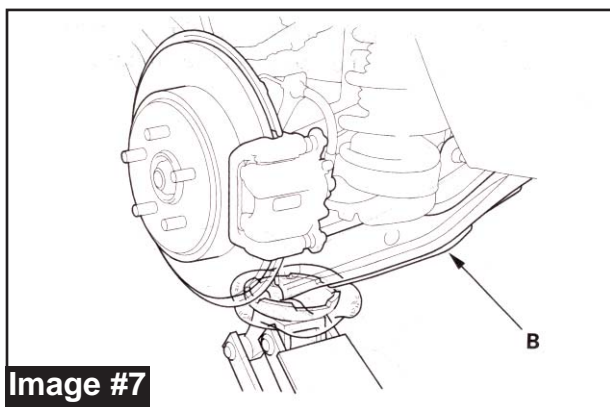
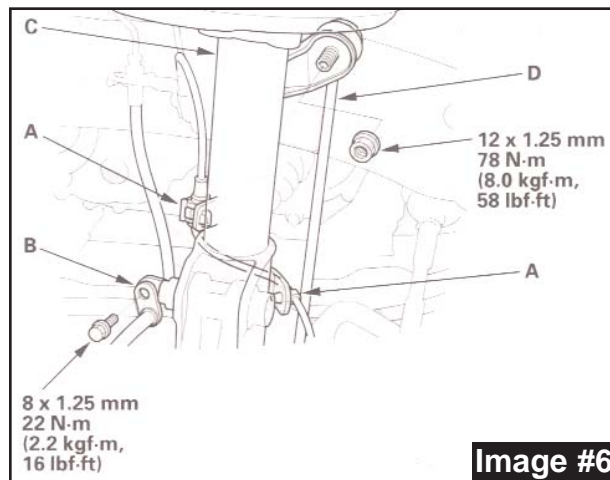

16. Hold adjusting bolt (A) on the lower A-Arm, and remove the self-locking nut (C) and adjusting cam (D). (See Image #10)
18. Remove adjusting bolt and lower A-Arm down.
19. Remove the three flange bolts (A) from top of the damper, remove damper assembly (B). (See Image #11)
20. Attach new rear spacer to the factory frame mount using the 10x30mm bolts with a 1.25 thread pitch provided. (See Image #12)
With upper bracket installed, attach damper using the 10x30mm bolts and nuts supplied. One washer will be used under the nut.
21. Re-Install lower A-Arm assembly in reverse order of removal. Torque all hardware to factory specs shown in previous images. With all parts installed, raise lower A-Arm so that vehicles weight is on damper assembly. Torque the 3 upper damper bolts to 45 Ft. Lbs.
22. With all parts installed and properly tightened, reinstall wheels and lower vehicle to the ground.

FINAL NOTES:

- After installation, a qualified alignment center is required to properly align the vehicle.
- Have Headlights adjusted to proper setting.
- With vehicle on the ground check clearances on all moving parts, wheels, tires, etc. Be sure to check brake lines for proper length and any damage.
- Re-Torque all bolts after the first 100 miles and periodically there after.

Seat Belts Save Lives, Please Wear Your Seat Belt!

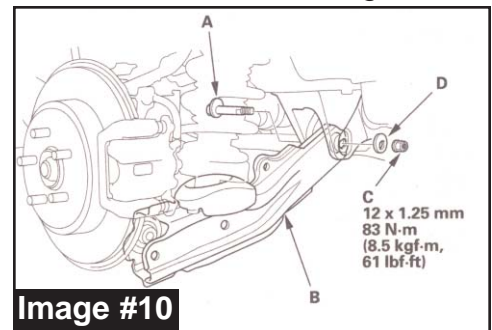

Image #10

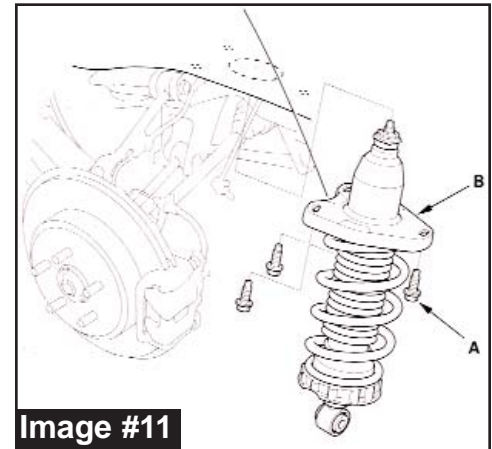

Image #11

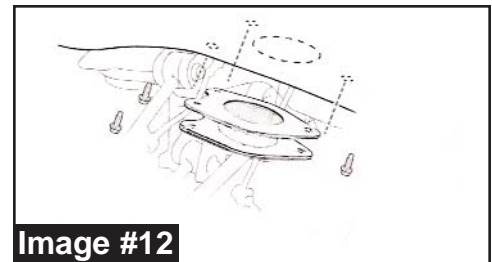

Image #12



HR 20